

REZANJE = 3,74 m ODP. ŠIRINA = 0,60 m ² REZANJE_VOZILA = 1,33 m ² ODP. C = 6,81 m ² NI = 1,50 m TAMRON = 0,96 m ² ODP. = 0,50 m ² PLANUM = 5,00 m AL_BAŠE = 5,00 m										
52.000										
CESTIŠÈÈ										
OD.OSI										
TEREN										
OD.OSI	6.881	61.861	61.818	61.861	0.000	61.853	0.000	61.850	2.500	61.743

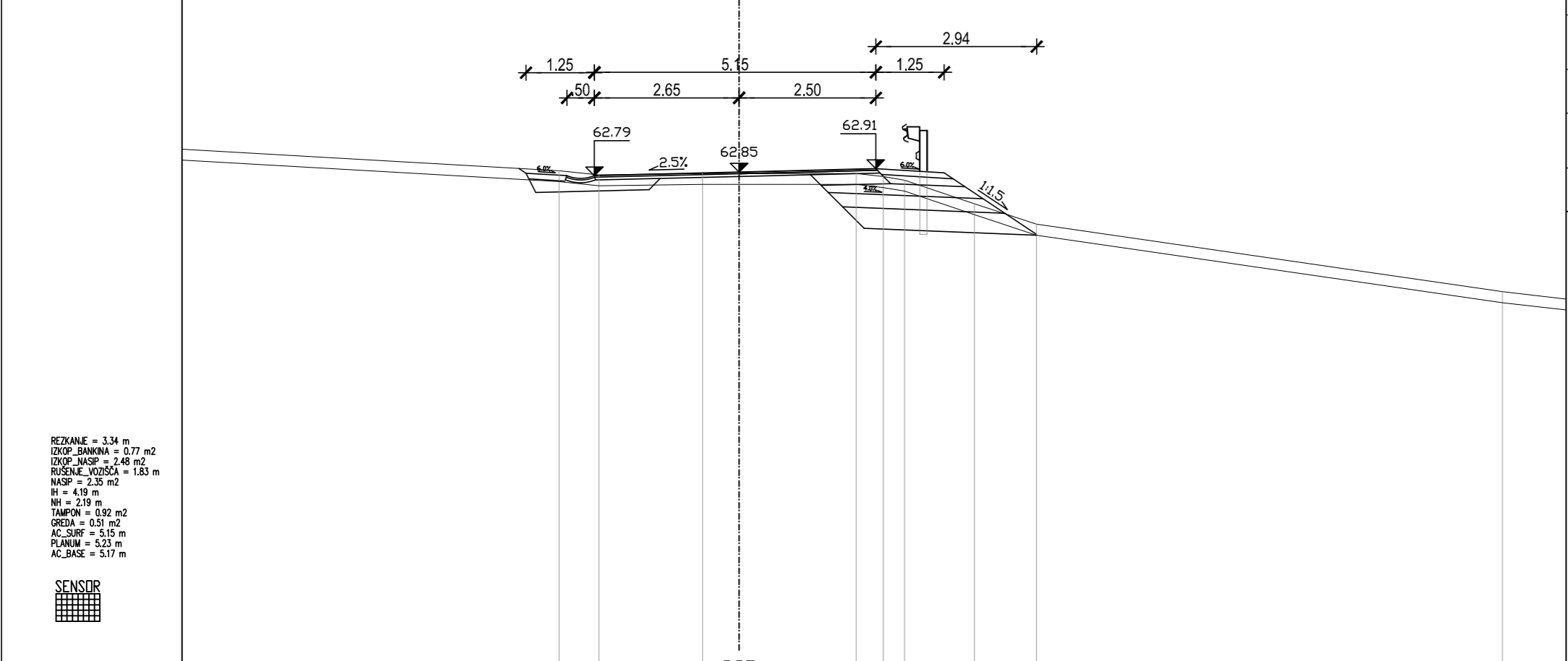

REZANJE = 3,34 m ODP. ŠIRINA = 0,77 m ² REZANJE_VOZILA = 1,46 m ² ODP. C = 5,28 m ² NI = 1,50 m TAMRON = 0,92 m ² ODP. = 0,51 m ² PLANUM = 5,21 m AL_BAŠE = 5,21 m										
53.000										
CESTIŠÈÈ										
OD.OSI										
TEREN										
OD.OSI	3.292	62.877	62.806	62.851	0.000	62.826	0.000	62.851	2.500	62.913

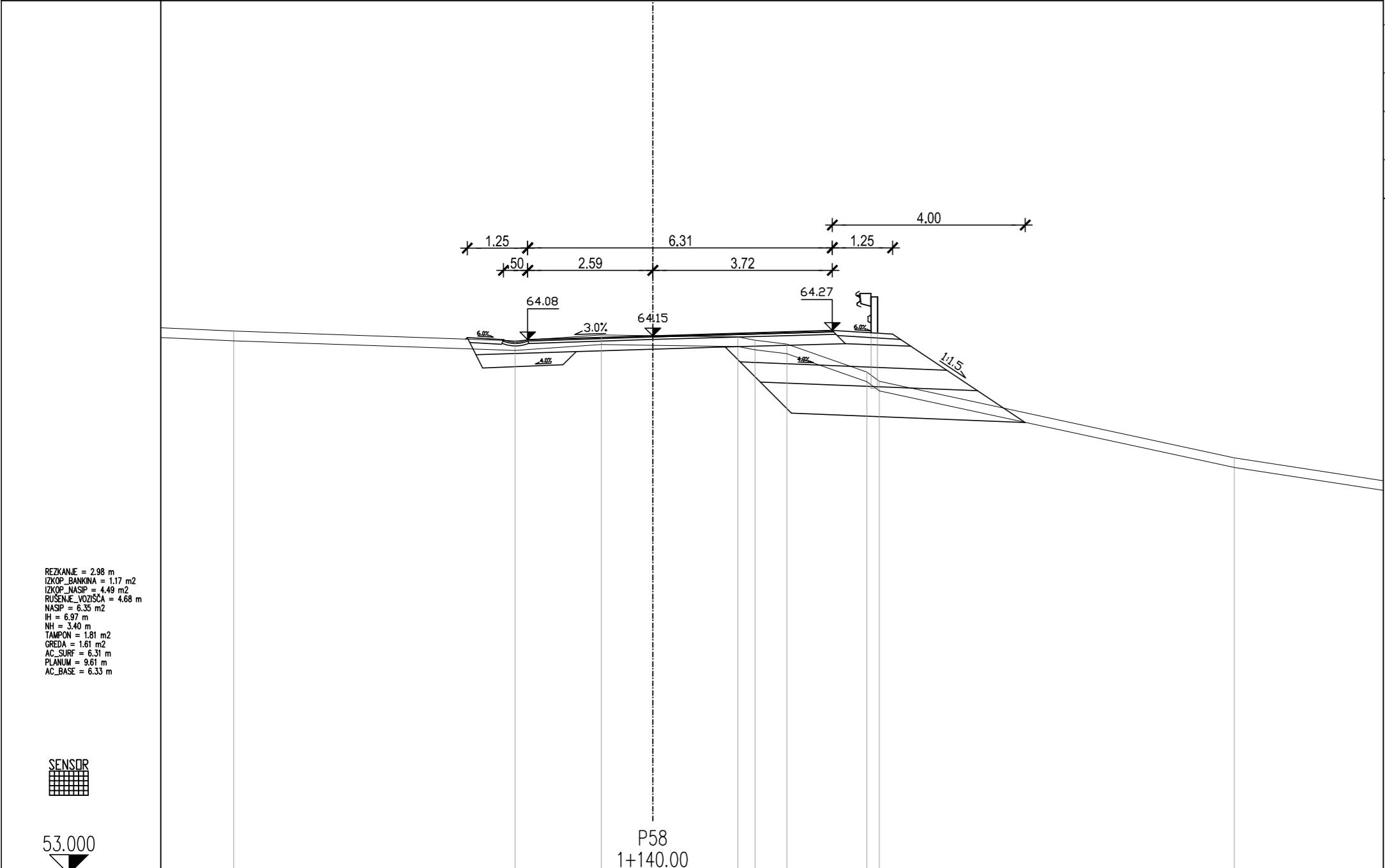

REZANJE = 2,88 m ODP. ŠIRINA = 1,17 m ² REZANJE_VOZILA = 4,49 m ² ODP. C = 5,17 m ² NI = 1,50 m TAMRON = 1,09 m ² ODP. = 1,41 m ² PLANUM = 4,51 m AL_BAŠE = 4,51 m										
53.000										
CESTIŠÈÈ										
OD.OSI										
TEREN										
OD.OSI	8.683	64.254	64.076	64.154	0.000	64.160	0.000	64.154	3.716	64.067

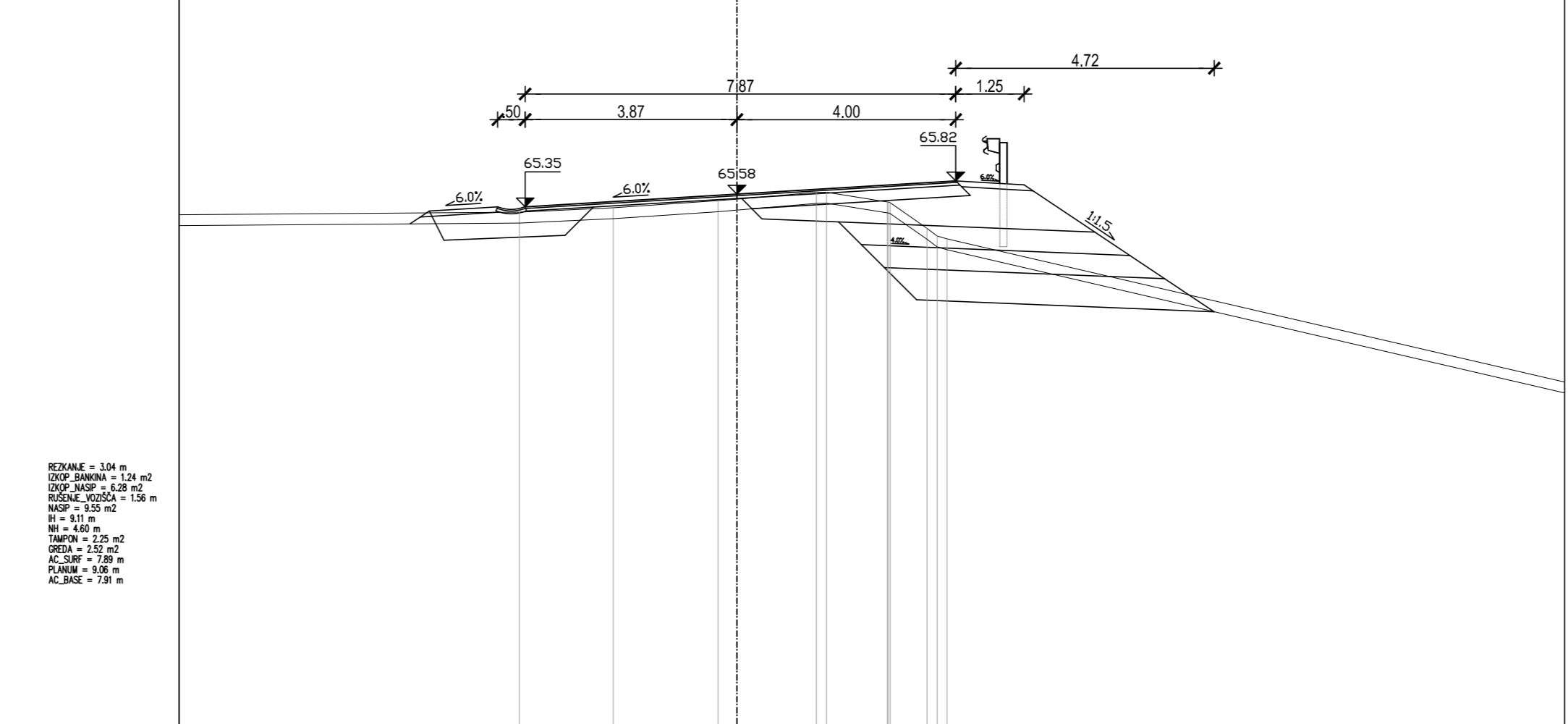

REZANJE = 3,04 m ODP. ŠIRINA = 1,14 m ² REZANJE_VOZILA = 2,28 m ² ODP. C = 6,02 m ² NI = 1,50 m TAMRON = 1,25 m ² ODP. = 1,15 m ² PLANUM = 5,00 m AL_BAŠE = 5,00 m										
52.000										
CESTIŠÈÈ										
OD.OSI										
TEREN										
OD.OSI	65.149	65.149	65.149	65.383	0.000	65.383	0.000	65.383	4.000	65.824

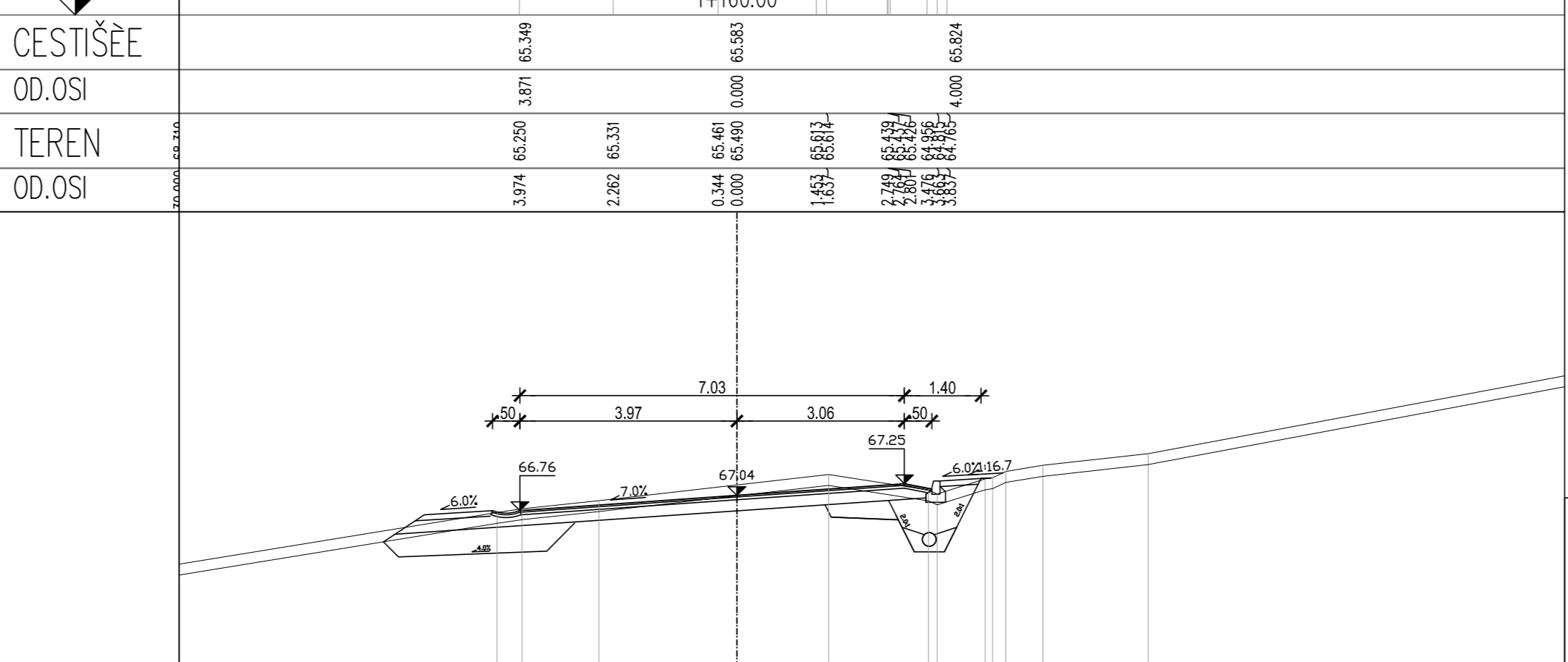

REZANJE = 5,64 m ODP. ŠIRINA = 2,18 m ² REZANJE_VOZILA = 3,78 m ² ODP. C = 4,92 m ² NI = 1,50 m TAMRON = 1,20 m ² ODP. = 1,10 m ² PLANUM = 5,00 m AL_BAŠE = 5,00 m										
59.000										
CESTIŠÈÈ										
OD.OSI										
TEREN										
OD.OSI	4.384	66.726	66.760	67.038	0.000	67.038	0.000	67.038	3.062	67.252

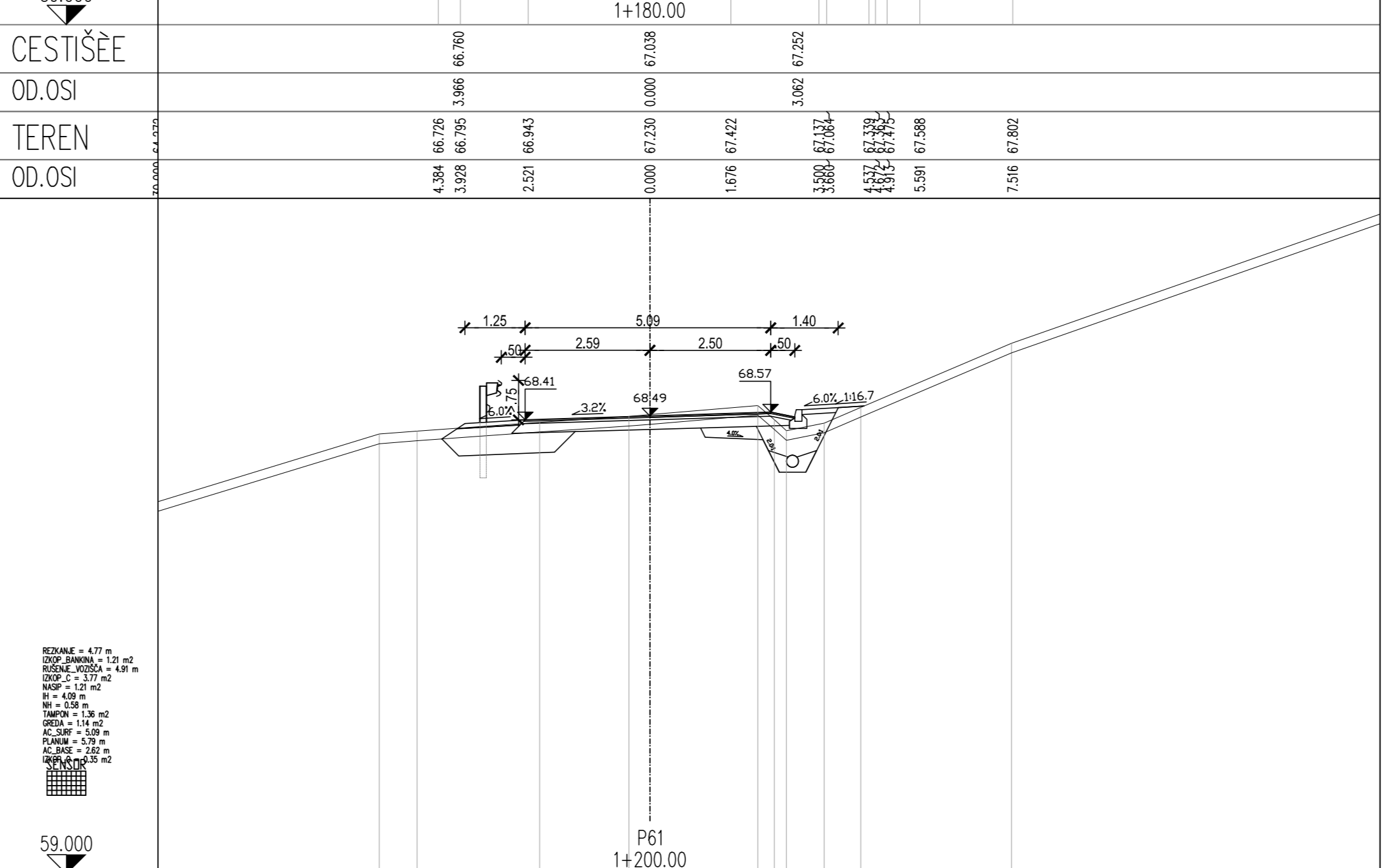



REZANJE = 4,77 m ODP. ŠIRINA = 1,51 m ² REZANJE_VOZILA = 4,81 m ² ODP. C = 3,17 m ² NI = 1,50 m TAMRON = 1,36 m ² ODP. = 1,14 m ² PLANUM = 5,50 m AL_BAŠE = 5,50 m										
59.000										
CESTIŠÈÈ										
OD.OSI										
TEREN										
OD.OSI	5.607	68.177	68.178	68.493	0.000	68.493	0.000	68.571	2.500	68.571

UREDITEV LOKALNE CESTE LC 284321 DORNBERK-RENÈE

NAÈRT VOZIŠÈA-REKONSTRUKCIJA SERPENTINE
PREÈNI PREREZ CESTE P56- P61

merilo: 1:100

št. spremembe	datum spremembe	opis spremembe	podpis
 			
odg. vodja projekta:	MATEJ BRÉŠAN, univ.dipl.inž.grad.		I2S G-2403
odp. projektant:	ANDRAŽ CEKET, univ.dipl.inž.grad.		I2S G-2435
izselek:	MIHAEL MLAKAR, dipl.inž.grad.		
investor / naroènik:	MESTNA OBÈINA NOVA GORICA, Trg Edvarda Kardelja 1, 5000 Nova Gorica		
vista projekta:	PZI		
vista naèrta:	3.1.2 Naèrt vozišèa		
naziv objekta:	UREDITEV LOKALNE CESTE LC 284321 Dornberk-Renèe		
vsobina nbsb:	NAÈRT VOZIŠÈA-Rekonstrukcija serpentine Preèni prerez ceste P56- P61		
datum:	št. projekta:	št. naèrta:	merilo:
April 2013 po recenziji	711/2	711/2-312	1:100
			132.1